

I B.Tech Regular Examinations, May/Jun 2008

ENGINEERING DRAWING

(Common to Computer Science & Engineering and Computer Science & Systems Engineering)

Time: 3 hours

Max Marks: 80

**Answer any FIVE Questions
All Questions carry equal marks**

1. Inscribe an ellipse in a parallelogram having sides 150mm and 100 mm long and an included angle of 120° . [16]
2. (a) The top view of a 75mm long line measures 55mm. The line is in the VP, its one end being 25mm above the HP, draw its projections.
(b) The front view of a line, inclined at 30° to the VP is 65mm long. Draw the projections of the line, when it is parallel to and 40mm above the HP., its one end being 30mm in front of the VP. [8+8]
3. A semi circular plate of 80mm diameter has its straight edge in the VP and inclined at 60° to the HP, the surface of the plate makes an angle of 30° with the VP. Draw its projections. [16]
4. A regular square prism lies its axis inclined at 60° to the HP and 30° to the VP. The prism is 60mm long and has a face width of 25mm. The nearest corner is 10mm away from the VP and the farthest shorter edge is 100mm from the HP. Draw the projections of the solid. [16]
5. A right circular cylinder diameter of base 50mm and length of axis 70mm, rests on HP on its base rim such that its axis is inclined at 45° to HP and the top view of the axis is inclined at 60° to the VP. Draw its projections. [16]
6. Draw the isometric projection of a hexagonal prism of side of base 35mm and altitude 50mm surmounting a tetrahedron of side 45mm such that the axes of the solids are collinear and at least one of the edges of the two solids are parallel. [16]
7. Three views of a machine part are shown in figure 7. Draw the isometric view of the part (all dimensions are in mm). [16]

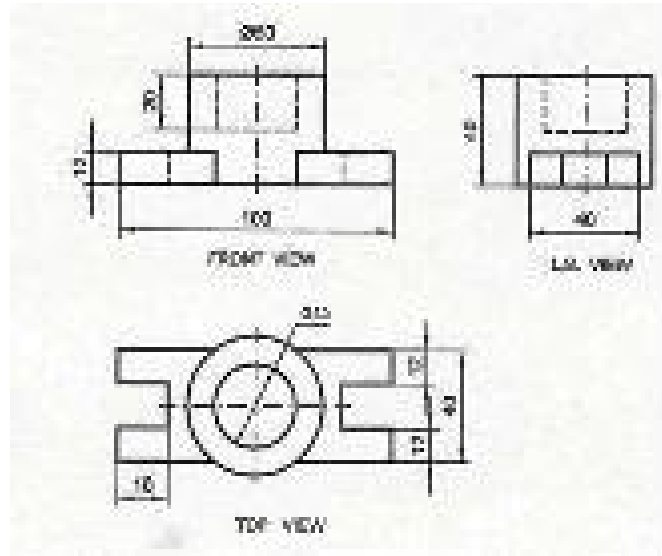

Figure 7

8. Draw the orthographic views of the object as shown in the figure 8. (all dimensions are in mm).

- (a) Front View
- (b) Top View
- (c) Side View.

[16]

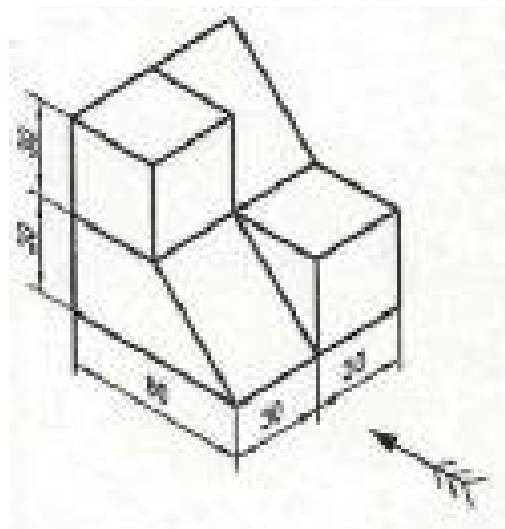

Figure 8

I B.Tech Regular Examinations, May/Jun 2008

ENGINEERING DRAWING

(Common to Computer Science & Engineering and Computer Science & Systems Engineering)

Time: 3 hours

Max Marks: 80

**Answer any FIVE Questions
All Questions carry equal marks**

1. Draw a straight line AB of any length. Mark a point F, 65mm from AB. Trace the paths of a point P moving in such away, that the ratio of its distance from the point F, to its distance from AB is 2:3. Draw a normal and a Tangent to the curve at a point on it, 50mm from F. [16]
2. (a) Two pegs fixed on a wall are 4.5 m apart. The distance between the pegs measured parallel to the floor is 3.6m. If one peg is 1.5 m above the floor, find the height of the second peg and the inclination of the line joining the two pegs, with the floor.
(b) A point P is 20mm below HP and lies in the third quadrant. Its shortest distance from xy is 40mm. Draw its projections. [10+6]
3. A composite plate of negligible thickness is made up of a rectangle 60mm × 40 mm, and a semi circle on its longer side. Draw its projections when the longer side is parallel to the HP and inclined at 45° to the VP, the surface of the plate making 30° angle with the HP. [16]
4. A hexagonal pyramid, base 25mm side and axis 50mm long, has an edge of its base on the ground. Its axis is inclined at 30° to the ground and parallel to the VP. Draw its projections. [16]
5. A right circular cone diameter of base 50mm and height 65mm, lies on one of its elements in HP such that the element is inclined to VP at 30°. Draw its projections. [16]
6. A square pyramid of side 30mm, axis length 50mm is centrally placed on top of a cube of side 50mm. Draw the isometric projections of solids. [16]
7. Two views of a casting are shown in figure 7. Draw the isometric view of the casting (all dimensions are in mm). [16]

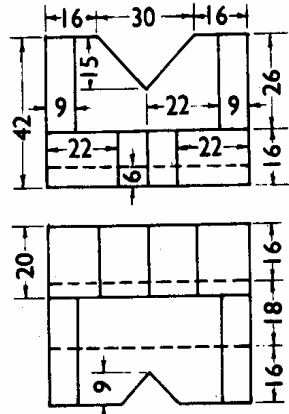

Figure 7

8. Draw the three views of the object shown in figure 8. (all dimensions are in mm).
[16]

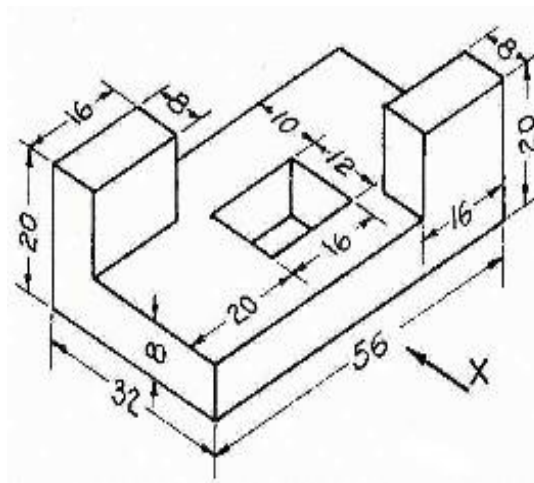

Figure 8

I B.Tech Regular Examinations, May/Jun 2008

ENGINEERING DRAWING

(Common to Computer Science & Engineering and Computer Science &
Systems Engineering)

Time: 3 hours

Max Marks: 80

Answer any FIVE Questions
All Questions carry equal marks

1. A fixed point is 75mm from a fixed straight line. Draw the locus of a point P moving such a way that its distance from the fixed straight line is equal to its distance from the fixed point. Name the curve. Draw a normal and tangent on the curve. [16]
2. A room measures 8m long, 5m wide and 4m high. An electric bulb hangs in the centre of the ceiling and 1m below it. A thin straight wire connects the bulb to a switch kept in one of corner of the room and 1.25m above the floor. Draw the projections of the wire, also determine its true length and slope with the floor. [16]
3. A circular plate of negligible thickness and 50mm diameter appears as an ellipse in the front view, having its major axis 50mm long and minor axis 30mm long. Draw its top view when the major axis of the ellipse is horizontal. [16]
4. A pentagonal prism is resting on one of the corners of its base on the HP. The longer edge containing that corner is inclined at 30° and the vertical plane containing that edge is inclined at 45° to the VP. Draw the projections of the solid. [16]
5. Two spheres of diameters 40mm and 20mm are placed on HP touching each other. Draw its projections when the line joining their centers in top view appears to be inclined 40° to XY line. [16]
6. A triangular prism of base edge 30mm and height 60mm stands on one of its corners on the ground with the axis inclined at 30° to the HP and 45° to the VP. The base of the object is nearer to VP compared to the top. Draw an isometric view of the object. [16]
7. Two views of a casting are shown in figure 7. Draw the isometric projection of the casting (all dimensions are in mm). [16]

I B.Tech Regular Examinations, May/June 2008

ENGINEERING DRAWING

(Common to Computer Science & Engineering and Computer Science & Systems Engineering)

Time: 3 hours

Max Marks: 80

Answer any FIVE Questions
All Questions carry equal marks

1. Draw a straight line AB of any length. Mark a point F, 65mm from AB. Trace the paths of a point P moving in such a way, that the ratio of its distance from the point F, to its distance from AB is 1. Draw a normal and a Tangent to the curve at a point on it, 50mm from F. [16]
2. A line AB, 90 mm long, is inclined at 45° to the HP and its top view makes an angle of 60° with the VP. The end A is in the HP and 12 mm in front of the VP. Draw its front view and find its true inclination with the VP. [16]
3. A regular hexagon of 40mm has a corner in the HP. Its surface is inclined at 45° to the HP and the top view of the diagonal through the corner which is in the HP makes an angle of 60° with the VP. Draw its projections. [16]
4. One end of a longer edge of a regular hexagonal prism of side of base 30mm and height 80mm is on the VP and the other end of the same edge is on the ground. The axis makes 30° to the VP and 40° to the ground. Draw its projections. [16]
5. An ash tray made up of a thin sheet of steel, is spherical in shape with flat, circular top of 68mm diameter and bottom of 52mm diameter and parallel to each other . The greatest diameter of it is 100mm. Draw the projections of the ash tray when its axis is parallel to the V P and ;
 - (a) Makes an angle of 60° with the HP
 - (b) Its base is inclined at 30° to the HP. [16]
6. A square pyramid of side 30mm, axis length 50mm is centrally placed on top of a cube of side 50mm. Draw the isometric projections of solids. [16]
7. Two views of a casting are shown in figure 7. Draw the isometric projection of the casting (all dimensions are in mm). [16]

